

Features

- Transformerless 2-wire to 4-wire conversion
- Battery and ringing feed to line
- Off-hook and dial pulse detection
- Ring ground over-current protection
- Adjustable constant current feed
- Relay drive output
- Power V_{Bat} Denial
- Wide operating range

Applications

Line interface for:

- PABX
- Intercoms
- Key Telephone Systems
- Control Systems

ISSUE 4

April 1995

Ordering Information

MH88612 20 Pin SIL Package

0°C to 70°C

Description

The SLIC provides a complete interface between a switching system and a subscriber loop. Functions provided include battery feed and ringing feed to the subscriber line, 2-Wire to 4-Wire hybrid interfacing, constant current feed and dial pulse detection. The device is fabricated using thick film hybrid technology in a 20-pin single in-line package.

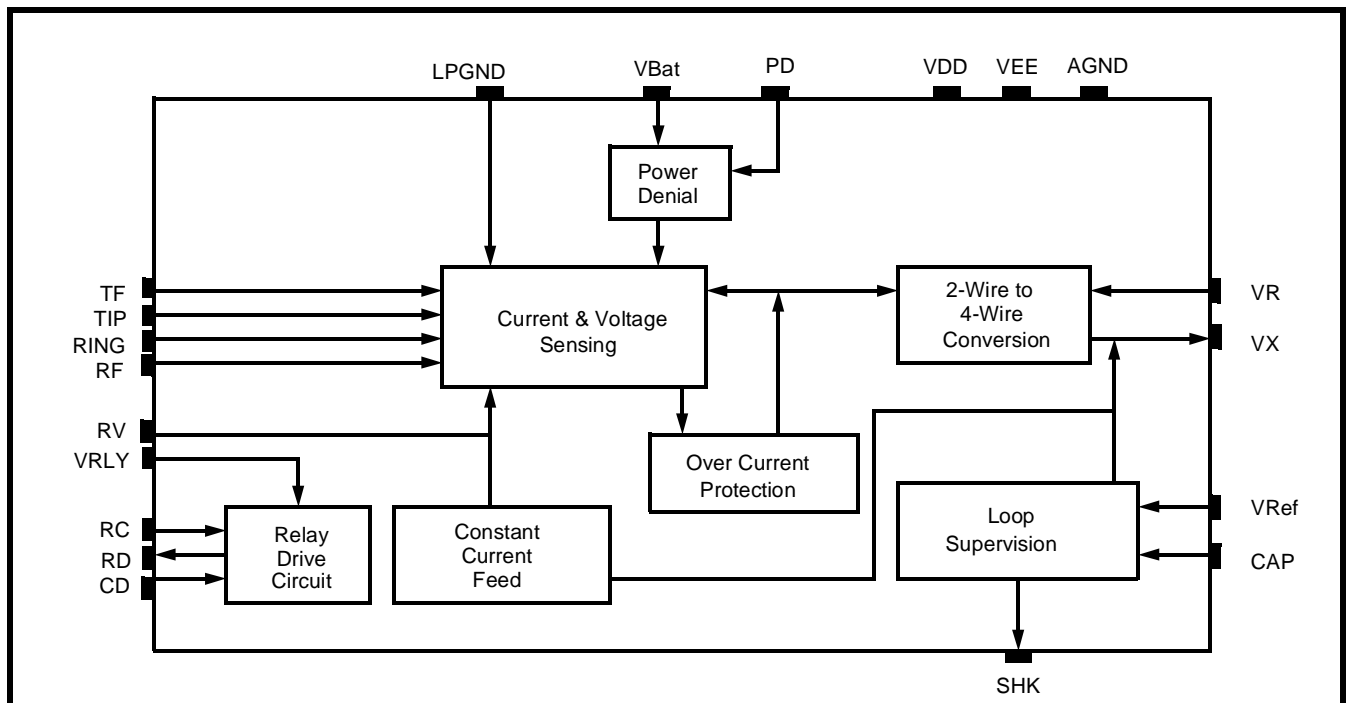

Figure 1 - Functional Block Diagram

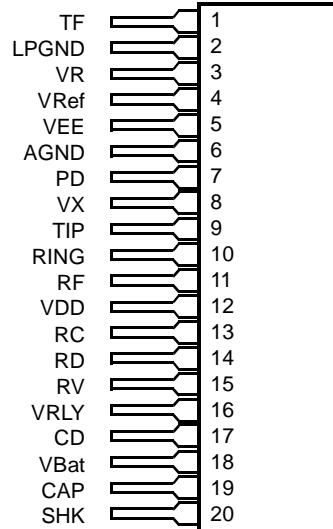

Figure 2 - Pin Connections

Pin Description

Pin #	Name	Description
1	TF	Tip Feed. Connects to external diode for protection.
2	LPGND	Loop Ground. is the system ground reference with respect to VBat. Normally tied with AGND.
3	VR	Voice Receive (input) is the 4 wire analog signal to the SLIC.
4	VRef	Voltage Reference (Input) to set the constant current feed to the subscriber line. Constant current feed can be adjusted by the input voltage on the V_{Ref} . This pin can also be grounded for normal 25 mA loop current.
5	VEE	Negative Power Supply Voltage (-5V).
6	AGND	Analog Ground (0V).
7	PD	Power Denial (Input). A logic high will isolate the battery voltage to Tip/Ring.
8	VX	Voice Transmit (Output) is the 4-wire analog signal from the SLIC.
9	TIP	Connects to the "Tip" lead of the telephone line .
10	RING	Connects to the "Ring" lead of the telephone line
11	RF	Ring Feed (Input) is normally connected to Ring relay for negative battery feed voltage and ringing voltage input.
12	VDD	Positive Power Supply Voltage (+5V).
13	RC	Relay Control (Input). Active high.
14	RD	Open collector sinks current when RC is at logic high.
15	RV	Ring Feed Voltage connects to pin 11 (RF) through a normally closed relay.
16	VRLY	Relay voltage Supply (+5V).
17	CD	Clamping Diode. Connects to GNDA.
18	VBat	Negative Battery Feed Supply Voltage (-48V).
19	CAP	Connects external capacitor to ground for ring trip.
20	SHK	Switch Hook Detect (Output). Active high.

Functional Description

The SLIC performs a transformerless 2-wire to 4-wire conversion of the analog signal. The 2-wire circuit is the balanced line going to the subscriber loop, while the 4-wire circuit is the audio signal going to and from devices such as the voice codec or switching circuit. The SLIC also provides a switch hook (SHK) status output which goes high when the telephone is set off-hook.

Constant Current Feed

The SLIC employs a complex feedback circuit to supply a constant feed current to the line. This is done by sensing the sum of the voltages across the internal feed resistors and comparing it to an input reference voltage (V_{Ref}) that determines the constant feed current. If V_{Ref} (pin 4) is externally grounded, the constant current is set at 25mA. For a constant current setting between 18mA and 30mA, V_{Ref} can be set between 8.75 Vdc and -6.35 Vdc. The relationship is defined by the equation:

$$I_{\text{LOOP}} = 25 - \frac{(V_{\text{Ref}})}{1.25} \text{ mA } (\pm 2 \text{ mA})$$

Switch Hook Detection

When the DC current exceeds an internal threshold level, the switch hook (SHK) will go high. If the loop resistance is so high that V_{BAT} can no longer supply the required amount of loop current as determined by constant current supply circuit, the output of the switch hook (SHK) will go low to indicate that the loop resistance is too high and the line is on hook.

Ringing And Ring Trip Detection

In Figure 3 a ringing signal (e.g. 90 V_{rms}=+/48Vdc) is applied to the line by disconnecting pin 15 (RV) from pin 11 (RF), and connecting the ringing voltage at pin 11 (RF) by use of the relay K1.

The SLIC can detect an off-hook condition during ringing but there is a large AC component which must be filtered out to give a true off-hook condition at SHK.

A 1.0μF capacitor connected from pin 19 (CAP) to ground will provide adequate attenuation when

ringing is applied. Once an off-hook condition has been detected a logic low should be applied to pin 13 (RC) which will deactivate the relay (K1) to disconnect the ringing voltage from pin 11 and reconnect to pin 15. At that time the SLIC will revert to constant current feed operation.

For applications requiring Dial Pulse Detection the Capacitor connection to ground should be controlled such that the capacitor is only connected during ringing.

During off-hook conditions (closed loop), the capacitor should be switched out. This can be performed using a transistor, relay or system drive output of a codec. Applying AGND to the Ring Trip Filter Control pin will switch in the filter, whilst removing AGND, (with the switch in a tri-state condition), will switch out the filter.

For applications using DTMF signalling, the capacitor can be permanently connected to ground.

Current Limit

The Tip or Ring may accidentally short to ground. In such a case, current will only flow through the feed resistor. This high current will be sensed and reduced by the current limit circuit to a lower value to protect the internal circuitry.

Power Denial

The power denial function is a feature of the MH88612 which allows for powering down of the subscriber loop. A logic high voltage applied to the power denial input effectively removes the battery voltage from the loop driver circuitry. The resulting I_{Loop} is negligible and power consumption is minimised. The power denial function is useful for disabling a loop which may have a ground fault.

Applications

Component List

- R1 = 1/4 W, $\pm 10\%$ 200 Ω
- R2 = 1/4W, $\pm 5\%$ 470 Ω
- C1 = Cap. Elec., 1.0 μ F, $\pm 10\%$, 25V
- D1,D2 = Diode Rect., 200V, 1A, IN4003
- K1 = Relay E/M, 5 or 6V, 1 Form C
- Options Decoupling capacitors (Cap. Cer 0.1 μ F, 50% $\pm 20\%$) should be added to V_{DD} , V_{EE} , V_{Bat} , V_{Ref} and V_{RLY} for extra protection of the hybrid.
- RV1, RV2 160 Vrms, 250V 10J
- D3, D4 Diode Rect., 200V, 1A 1N4003.

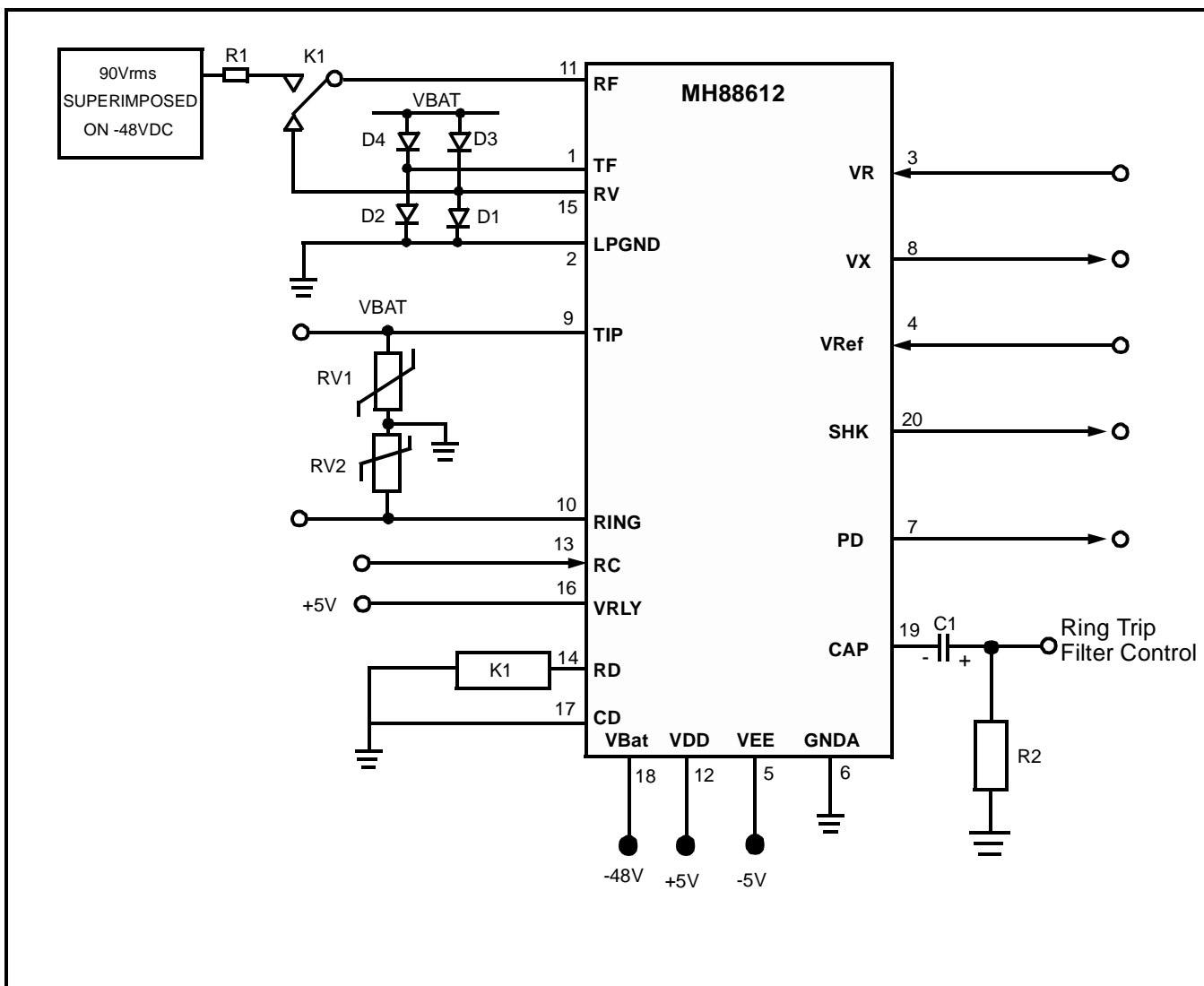

Figure 3 - Application Circuit

Absolute Maximum Ratings*

	Parameter	Symbol	Min	Max	Units
1	DC Supply Voltage LPGND = AGND	V_{DD}	0.3	+15	V
		V_{EE}	-15	+0.3	V
		V_{Bat}	-60	+0.3	V
		V_{RLY}	-0.3	+40	V
		V_{Ref}	-60	+15	V
2	Storage Temperature	T_S	-40	100	°C
3	Package Power Dissipation	PD		2	W

* Exceeding these values may cause permanent damage. Functional operation under these conditions is not implied.

Recommended Operating Conditions

	Parameter	Sym	Min	Typ ^a	Max	Units	Comments
1	Operating Supply Voltage	V_{DD}	4.75	5.0	5.25	V	
		V_{EE}	-4.75	-5.0	-5.25	V	
		V_{Ref}		0		V	Adjustable
		V_{Bat}	-27	-48	-60	V	
		V_{RLY}		5		V	
2	Operating Temperature	T_O	0		70	°C	

a. Typical figures are at 25°C with nominal $\pm 5V$ supplies and are for design aid only; not guaranteed and not subject to production testing.

DC Electrical Characteristics[†] - Voltages are with respect to GNDA unless otherwise stated.

	Characteristics	Sym	Min	Typ [‡]	Max	Units	Test Conditions
1	Supply Current V_{DD} V_{EE} V_{Bat}	I_{DD} I_{EE} I_{Bat}		5.8 -2.6		mA mA μ A	PD = Logic High
2	Power Consumption	P_C		210 1410		mW mW	Standby Active
3	Constant Current Line Feed	I_{Loop}	23	25	27	mA	$V_{Ref} = AGND$ $V_{Bat} = -48V$
4	Adjustable Loop Current Range	I_{Loop}	18		30	mA	Adjustable with Ext. V_{Ref} input, $V_{Bat} = -48V$
5	Operating Loop Resistance	R_{Loop}			1200	Ω	$V_{Bat} = -48V @ I_{Loop} = 18mA$, R_{Loop} includes telephone set
6	Ring Ground Over-Current protection				40	mA	
7	Off-Hook Detect Output Low Voltage (On-hook) Output High Voltage (Off-hook)	V_{OL} V_{OH}	2.7		0.4	V V	Active high logic
8	Off- Hook Detect Output Low Current (on-hook) Output High Current. (off-hook)	I_{OL} I_{OH}			8 -400	mA μ A	
9	RC, PD Control Input Input Low Volt. (no activation) Input High Volt. (activation)	V_{IL} V_{IH}	2.0		0.7	V V	Active high logic
10	RC, PD control Input Input Low Current (no activation) Input high current (activation)	I_{IL} I_{IH}			-50 50	μ A mA	

[†] DC Electrical Characteristics are over recommended operating supply voltages.

[‡] Typical figures are at 25°C with nominal $\pm 5V$ supplies and are for design aid only.

AC Electrical Characteristics

	Characteristics	Sym	Min	Typ*	Max	Units	Test Conditions
1	Ring Voltage (rms)	V_{RING}	17		90 25	V_{rms} Hz	Superimposed on $V_{BAT} = -48V$
2	Ringer Equivalence Number	REN			3		
3	Ring Trip Detect time			200		ms	
4	Input AC Impedance 2-wire	Z_{in}		600		Ω	
5	Input Impedance at V_R			100		k Ω	
6	Output Impedance at V_x			10		Ω	
7	Gain 2-wire to V_x Gain relative to Gain @ 1kHz			-1.0 ± 0.1		dB	Input 3dBm, 1kHz across Tip and Ring, 300-3400 Hz
8	Gain V_R to 2-wire Gain relative to Gain @ 1kHz			-1.0 ± 0.15		dB dB	(Input 1.0 V_{rms} 1kHz at V_R $Z_{Load} = 600\Omega$ 300 - 3400 Hz 600 Ω
9	2-wire Return Loss over 300-3400Hz		20	30		dB	Input 0.5 V_{rms} , 1kHz across Tip and Ring, $Z_{Load} = 600\Omega$
10	Transhybrid Loss	THL	20	30		dB	Input 0.5 V_{rms} , 1kHz at V_R $Z_{Load} = 600\Omega$
11	Longitudinal to Metallic Balance over 300-3400 Hz		50	55		dB	Input 0.5 V_{rms}
12	Total Harmonic Distortion at V_x at Tip and Ring	THD		0.1 0.1	1.0 1.0	% %	Input 3dBm, 1 kHz across Tip and Ring, Input 1.0 V_{rms} 1kHz at V_R
13	Common Mode Rejection Ratio 2-wire to V_x	CMRR	40	50		dB	Input 0.5Vrms, 1kHz
14	Idle channel Noise (at V_x)	Nc			12	dBrnC	C- Message
15	Power supply rejection ratio V_{DD} V_{EE} V_{Bat}	PSRR	26 26 26			dB dB dB	1 V_{PP} ripple, 1kHz on $V_{DD}/V_{EE}/V_{BAT}$, measure at V_x and across Tip and Ring

* Typical figures are at 25°C and are for design aid only.

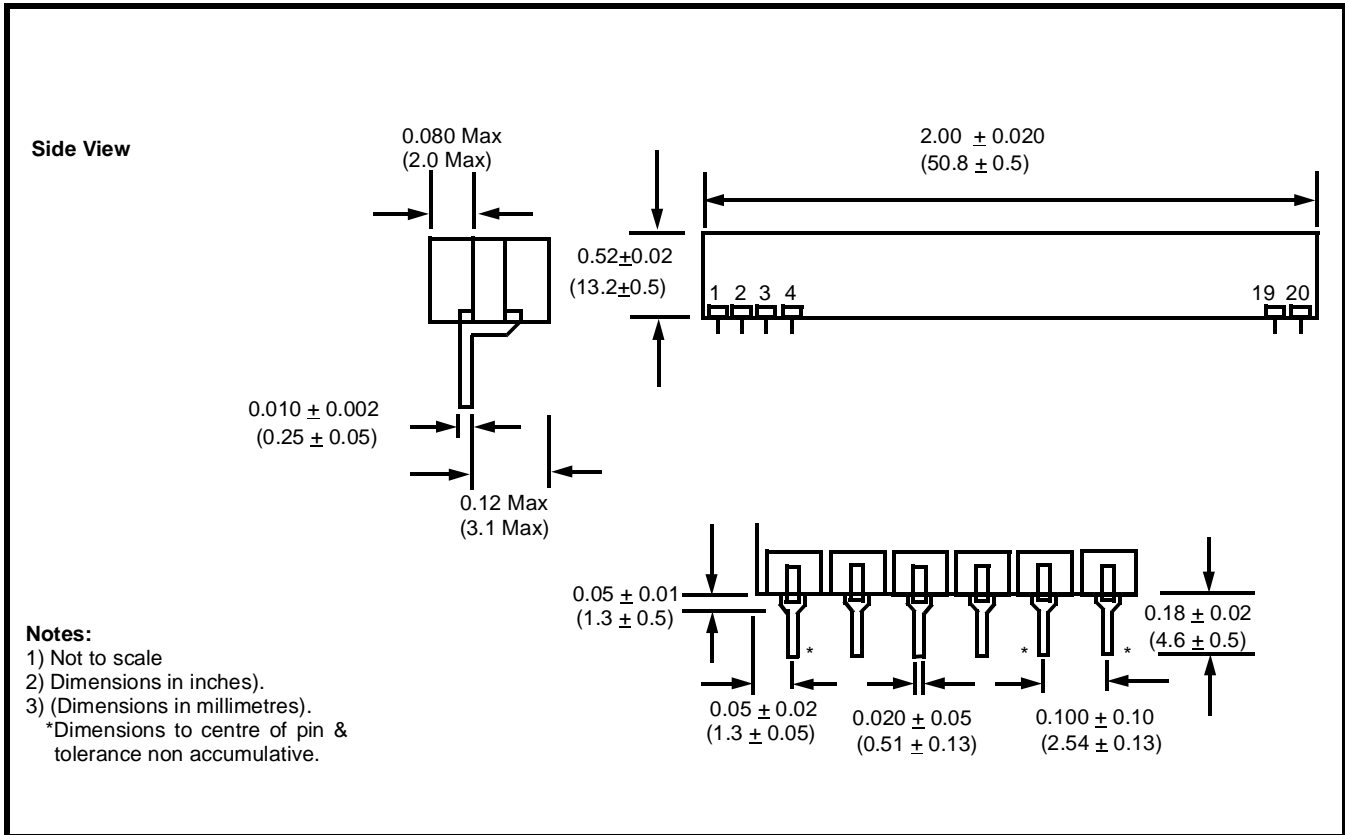

Figure 4 - Mechanical Data

This datasheet has been download from:

www.datasheetcatalog.com

Datasheets for electronics components.